

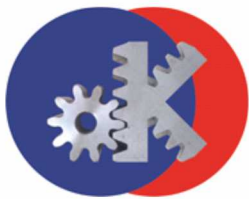

www.kramsan.com

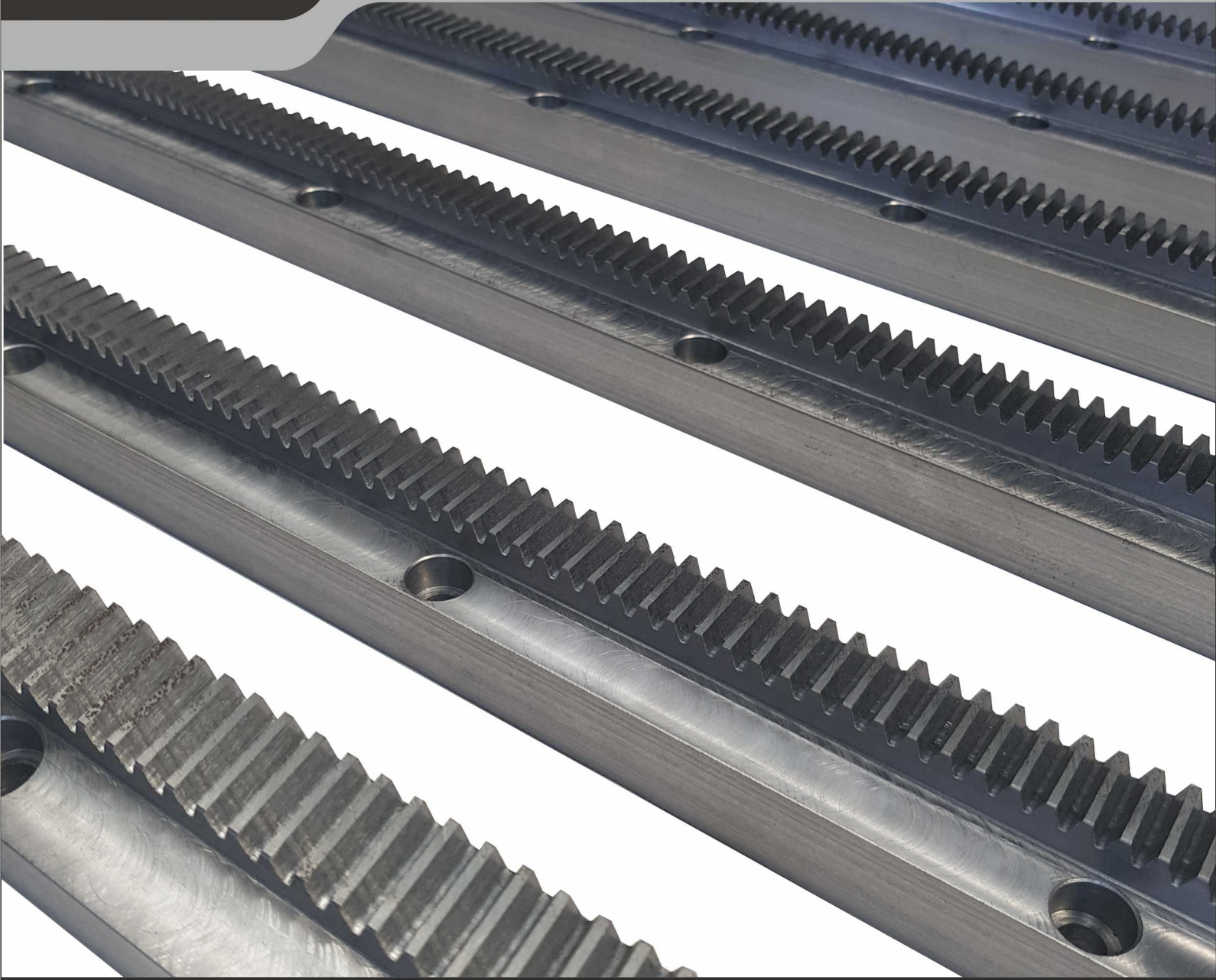

KRAMSAN
MAKINA MÜHENDİSLİK

KRAMAYER DİŞLİ



KRAMSAN MAKİNA MÜHENDİSLİK

KRAMSAN MAKİNA

Kurulduğu 2008 yılından bu güne, girişimci ve yenilikçi yapısıyla teknolojik alanda ki gelişmeleri, tüm iş süreçlerine süratle adapte eden firmamız; müşterilerine kramayer dişli grubunda 600m. kapalı, 150 m. açık alanda faaliyete göstermektedir.

Kurulduğu günden bu yana faaliyet gösterdiği sektörde başarılı ve öncü çalışmalarıyla sürekli kendini yenilemekte, müşterilerinin talep ve beklentilerinin ne olduğunu anlayıp yaratıcı çözümler bularak ve kendimizi sürekli geliştirmeye çalışarak, müşterilerimizin başarıya ulaşmalarını ve en yüksek kaliteye sahip olmalarını sağlamaktadır.

Siz değerli dostlarımıza hizmet vermek bizim için bir şereftir. Soru ve görüşleriniz için lütfen bizi aramaktan çekinmeyiniz.

MİSYONUMUZ;

Tüm beklentilere cevap veren projeler hazırlayıp, kaliteli ve güvenilir ürünler üretmektir.

VİZYONUMUZ;

İnsan ve doğa sağlığını ön planda tutup yeni araştırmalar yaparak, dünya çapında sektörde öncü kuruluş olmaktır.

YÖNETİM POLİTİKAMIZ;

Müşteri tatmininin sürekliliğini sağlayabilmek için yüksek üretim ve hizmet teknolojisine yatırım yapmak,
Her zaman siz değerli dostlarımıza karşı sorumlu ve şeffaf bir yapıda olmak.

YÖNETİM KURULU BAŞKANI

Abdülkadir KOCA



ANKARA

www.kramsan.com

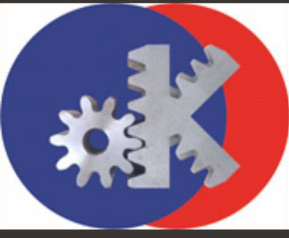

KRAMSAN MAKİNA MÜHENDİSLİK

FAALİYET ALANLARI



- CNC KREMAYER TEZGAHLARINDA YÜKSEK HASSASİYET İLE 0.5 MODÜLDEN 30 MODÜLE KADAR KREMAYER DİŞLİ VE KARŞILIKLARININ İMALATI YAPILMAKTADIR.
- STANDAR ÖLÇÜ VE MODÜLLERDE STOKLARIMIZ MEVCUTTUR.



- 0.5 MODÜLDEN 20 MODÜL ARASI 0-25 DERECEYE KADAR HELİS KREMAYER İMALATI YAPIYORUZ.
- MALZEME BOYLARI 1000mm-2000mm-3000mm



- 10mm ÇAPTAN 300mm ÇAP ÖLÇÜSÜNE KADAR YUVARLAK KREMAYER YAPIYORUZ.



- ÖLÇÜ , MODÜL, MALZEME KALINLIĞI, MALZEME BOYU , MALZEME ŞEKLİ , MALZEME CİNSİ NE OLURSA OLSUN SİZ TASARLAYIN BİZ ÜRETELİM.



- İNDÜKSİYON İŞLEMİ İLE ÜRÜNLERİ 55HRc SERTLİĞE KADAR SERTLEŞTİRİYORUZ.



- İSTER YENİ MAKİNA TASARLAYIN İSTER MAKİNANIZI REVİZE EDİN
- TÜM MERMER KESME VE BİÇİMLENDİRME MAKİNALARINDA KULLANILAN KRAMAYERLER İMALATIMIZDA MEVCUT.



- TÜM PLATFORM VE LİFT KRAMAYERLERİ STOKLARIMIZDA MEVCUTTUR.



- HER ÇEŞİT HİYAP İÇİN KREMAYER DİŞLİ YAPIYORUZ.



- TÜM MATKAP TEZGAHLARINA UYGUN KREMAYER DİŞLİ İMALATI YAPIYORUZ.



- TÜM TORNA TEZGAHLARINA UYGUN KREMAYER DİŞLİ İMALATI YAPIYORUZ.



- 0,5 MODÜLDEN 20 MODÜLE KADAR PİNYON DİŞLİ VE KREMAYER KARŞILIKLARI İMALATI YAPIYORUZ.
- ÇEŞİTLİ ÖLÇÜLERDE STOKLARIMIZ MEVCUTTUR.
- STOK BİLGİSİ İÇİN LÜTFEN İLETİŞİME GEÇİNİZ.



- 0,5 MODÜLDEN 20 MODÜLE KADAR HELİS DİŞLİ İMALATI YAPIYORUZ.
- ÇEŞİTLİ ÖLÇÜLERDE STOKLARIMIZ MEVCUTTUR.
- STOK BİLGİSİ İÇİN LÜTFEN İLETİŞİME GEÇİNİZ.

ANKARA

www.kramsan.com

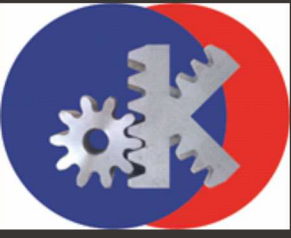

KRAMSAN MAKİNA MÜHENDİSLİK

ÜRÜNLERİMİZ



ANKARA

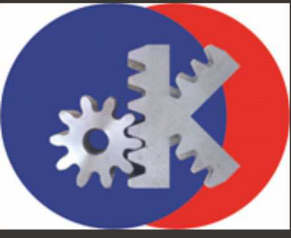

KRAMSAN MAKİNA MÜHENDİSLİK

MAKİNA PARKURU



egw 1750



Knapp auto 1750



A.MANNESMANN 2000

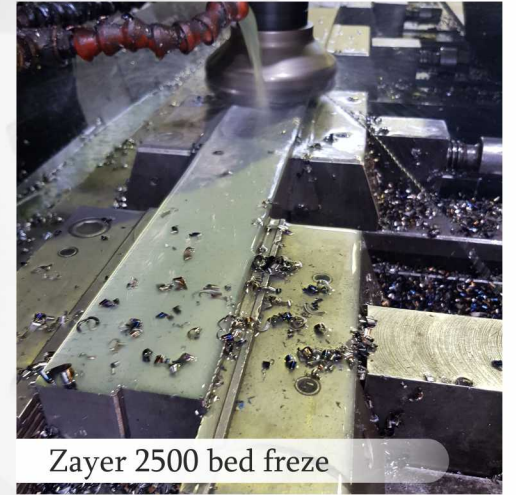

Zayer 2500 bed freze



Knapp auto 1750



Knapp auto 1750

ANKARA

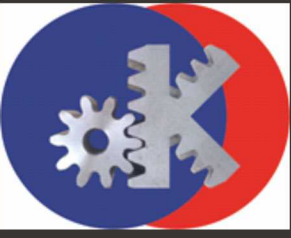

KRAMSAN MAKİNA MÜHENDİSLİK

MAKİNA PARKURU



KRS 3700 MN30



Kesel L93 CNC MN20



Knapp NC 1750



Knapp auto 1750



Kalıpcı boy freze



Mte bed freze 3200

ANKARA

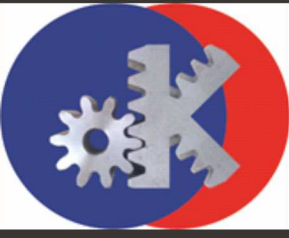

DÜZ KRAMAYER ÖLÇÜLERİ

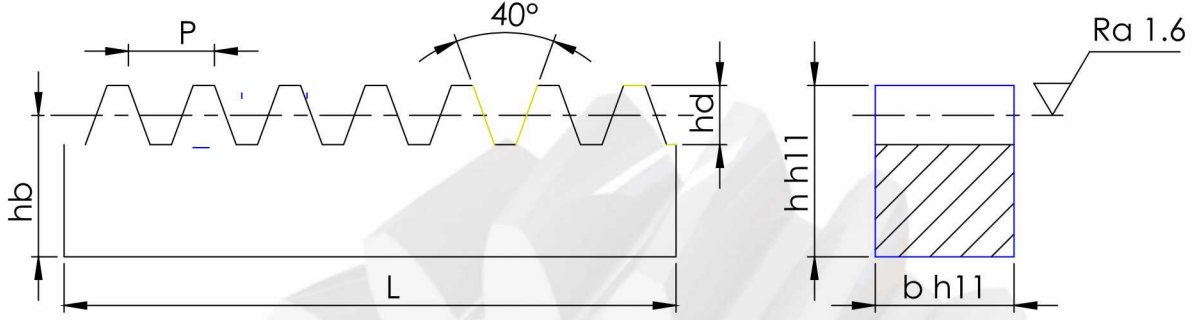

Malzeme - ck45 -C1040
Kalite - Q9-Q8

Yüzeyi - Soğuk çekme ham (h11)
Renk - Siyah

Kod	Modül m	Diş z	Adım p	Kalınlık b	Yükseklik h	hb	hd	Boy L (mm)	Stok
15X15X999M1_H	1	318	3.141	15	15	14	2.167	999	√
15X15X1998M1_H	1	636	3.141	15	15	14	2.167	1998	√
15X15X999M1.5_H	1.5	212	4.712	17	17	15.5	3.250	999	√
15X15X999M1.5_H	1.5	424	4.712	17	17	15.5	3.250	1998	√
20X20X999M2_H	2	159	6.283	20	20	18	4.334	999	√
20X20X1998M2_H	2	318	6.283	20	20	18	4.334	1998	√
20X20X1998M2.5_H	2.5	127	7.854	20	20	17.5	5.417	997.46	√
20X20X1995M2.5_H	2.5	254	7.854	20	20	17.5	5.417	1994.9	√
25X25X997.5M2.5_H	2.5	127	7.854	25	25	22.5	5.417	997.46	√
25X25X1995M2.5_H	2.5	254	7.854	25	25	22.5	5.417	1994.9	√
25X25X999M3_H	3	106	9.425	25	25	22	6.501	999	√
25X25X1998M3_H	3	212	9.425	25	25	22	6.501	1998	√
30X30X999M3_H	3	106	9.425	30	30	27	6.501	999	√
30X30X1998M3_H	3	212	9.425	30	30	27	6.501	1998	√
40X40X999M3_H	3	106	9.425	40	40	37	6.501	999	√
40X40X1998M3_H	3	212	9.425	40	40	37	6.501	1998	√

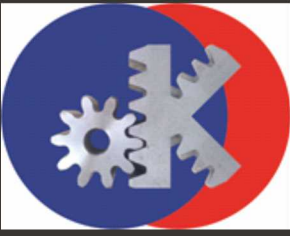

KRAMSAN MAKİNA MÜHENDİSLİK

DÜZ mn4 KRAMAYER ÖLÇÜLERİ

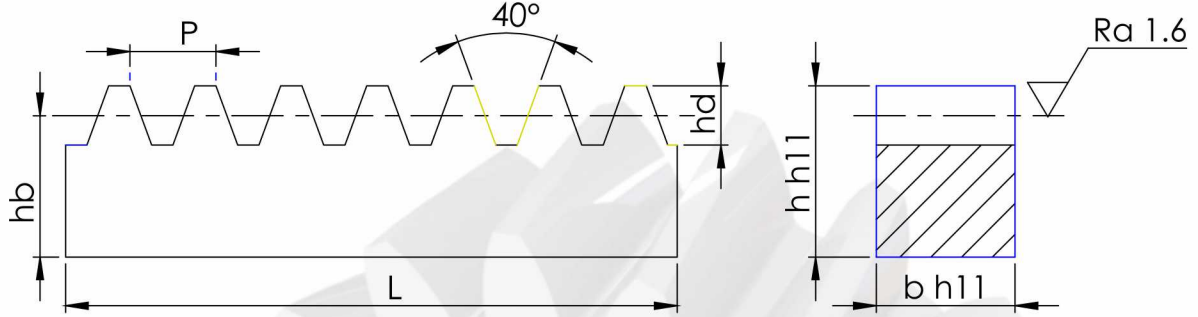

Malzeme - ck45 -C1040
Kalite - Q9-Q8

Yüzeyi - Soğuk çekme ham (h11)
Renk - Siyah

Kod	Modül m	Diş z	Adım p	Kalınlık b	Yükseklik h	hb	hd	Boy L (mm)	Stok
22X22X999M4-H	4	80	12.566	22	22	18	8,668	1005.3	√
22X22X1998M4-H	4	159	12.566	22	22	18	8,668	1998	√
25X25X999M4-H	4	80	12.566	25	25	21	8,668	1005.3	√
25X25X999M4-H	4	159	12.566	25	25	21	8,668	1998	√
30X30X999M4-H	4	80	12.566	30	30	26	8,668	1005.3	√
30X30X1998M4-H	4	159	12.566	30	30	26	8,668	1998	√
40X40X1998M4-H	4	80	12.566	40	40	36	8,668	1005.3	√
40X40X1995M4-H	4	159	12.566	40	40	36	8,668	1998	√
50X50X997.5M4-H	4	80	12.566	50	50	46	8,668	1005.3	√
50X50X1995M4-H	4	159	12.566	50	50	46	8,668	1998	√
60X60X999M4-H	4	80	12.566	60	60	56	8,668	1005.3	√
60X60X1998M4-H	4	159	12.566	60	60	56	8,668	1998	√
8X30X999M4-H	4	80	12.566	8	30	26	8,668	1005.3	√
10X30X1998M4-H	4	80	12.566	10	30	26	8,668	1005.3	√
12X30X999M4-H	4	80	12.566	12	30	26	8,668	1005.3	√
15X30X1998M4-H	4	80	12.566	15	30	26	8,668	1005.3	√

ANKARA

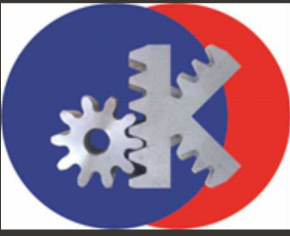

HELİS KRAMAYER ÖLÇÜLERİ

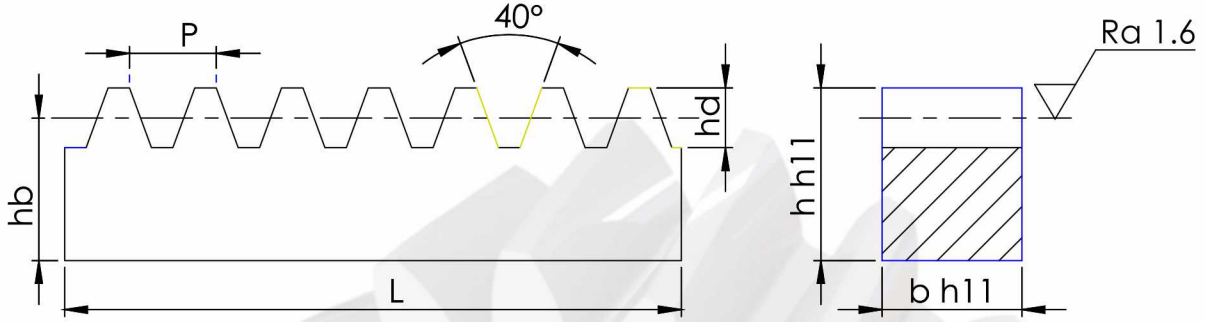

Malzeme - ck45 -C1040

Kalite - Q8 - Q7

Yüzeyi - Soğuk çekme ham (h11)

Renk - Siyah

Kod	Modül m	Diş z	Adım p	Kalınlık b	Yükseklik h	hb	hd	Boy L (mm)	Stok
15X15X999M1-H	1	300	3,333	15	15	14	2.167	1000	√
15X15X1998M1-H	1	600	3,333	15	15	14	2.167	2000	√
15X15X999M1.5-H	1.5	200	5.000	17	17	15.5	3.250	1000	√
15X15X999M1.5-H	1.5	400	5.000	17	17	15.5	3.250	2000	√
20X20X999M2-H	2	150	6.666	20	20	18	4.334	1000	√
20X20X1998M2-H	2	300	6.666	20	20	18	4.334	2000	√
20X20X1998M2.5-H	2,5	120	8.333	20	20	17.5	5.417	1000	√
20X20X1995M2.5-H	2,5	240	8.333	20	20	17.5	5.417	2000	√
25X25X997.5M2.5-H	2.5	120	8.333	25	25	22.5	5.417	1000	√
25X25X1995M2.5-H	2.5	240	8.333	25	25	22.5	5.417	2000	√
25X25X999M3-H	3	100	10.000	25	25	22	6.501	1000	√
25X25X1998M3-H	3	200	10.000	25	25	22	6.501	2000	√
30X30X999M3-H	3	100	10.000	30	30	27	6.501	1000	√
30X30X1998M3-H	3	200	10.000	30	30	27	6.501	2000	√
40X40X999M3-H	3	100	10.000	40	40	37	6.501	1000	√
40X40X1998M3-H	3	200	10.000	40	40	37	6.501	2000	√

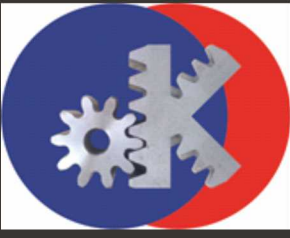

KRAMSAN MAKİNA MÜHENDİSLİK

HELİS KRAMAYER ÖLÇÜLERİ

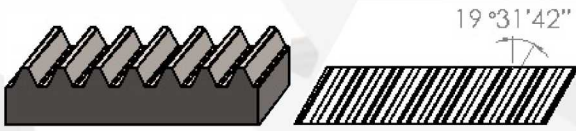
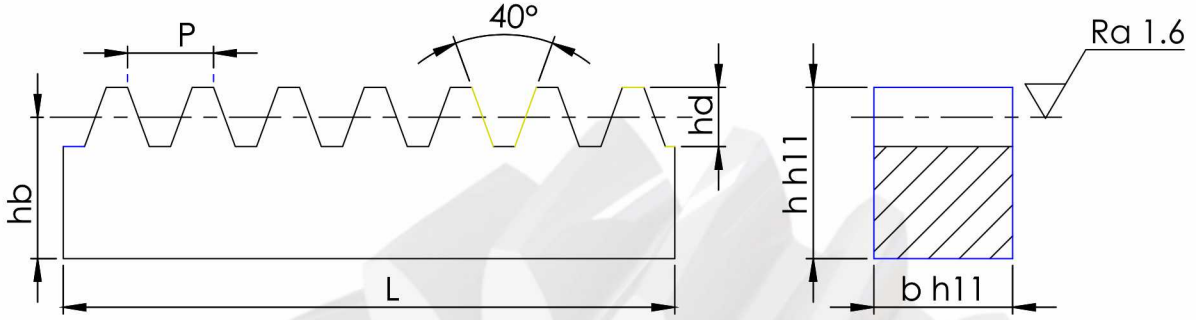

Malzeme - ck45 - C1040 - 4140
Kalite - Q7 hatve toleransı 0,003mm
Yüzeyi - frezelenmiş
Sertlik - İndüksiyon (Talebe göre)
40-55 HRC
Stok bilgisi için iletişime geçiniz

Kod	Modül m	Diş z (1mt'de)	Adım p	Kalınlık b	Yükseklik h	hb	hd	Boy L (mm)	Stok
15X15XM1-FR HLS	1	300	3,333	15	15	14	2.167	1-2-3	√
16X16XM1-FR HLS	1	300	3,333	16	16	15	2.167	1-2-3	√
17X17XM1.5-FR HLS	1.5	200	5.000	17	17	15.5	3.250	1-2-3	√
18X18XM1.5-FR HLS	1.5	200	5.000	18	18	16.5	3.250	1-2-3	√
20X20XM2-FR HLS	2	150	6.666	20	20	18	4.334	1-2-3	√
24X24XM2-FR HLS	2	150	6.666	24	24	22	4.334	1-2-3	√
25X25XM2-FR HLS	2	150	6.666	25	25	23	4.334	1-2-3	√
25X25XM2,5-FR HLS	2,5	120	8.333	25	25	22.5	5.417	1-2-3	√
29X29XM2.5-FR HLS	2.5	120	8.333	29	29	26.5	5.417	1-2-3	√
30X30XM2.5-FR HLS	2.5	120	8.333	30	30	27.5	5.417	1-2-3	√
25X25XM3-FR HLS	3	100	10.000	25	25	22	6.501	1-2-3	√
29X29XM3-FR HLS	3	100	10.000	29	29	26	6.501	1-2-3	√
30X30XM3-FR HLS	3	100	10.000	30	30	27	6.501	1-2-3	√
39X39XM4-FR HLS	4	75	13.333	39	39	35	6.501	1-2-3	√
40X40XM4-FR HLS	4	75	13.333	40	40	36	6.501	1-2-3	√
50X50XM5-FR HLS	5	60	16.666	50	50	45	6.501	1-2-3	√

ANKARA

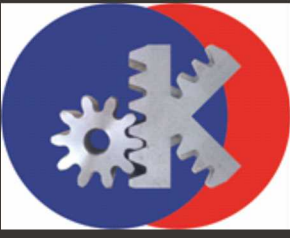

BÜYÜK MODÜLLER

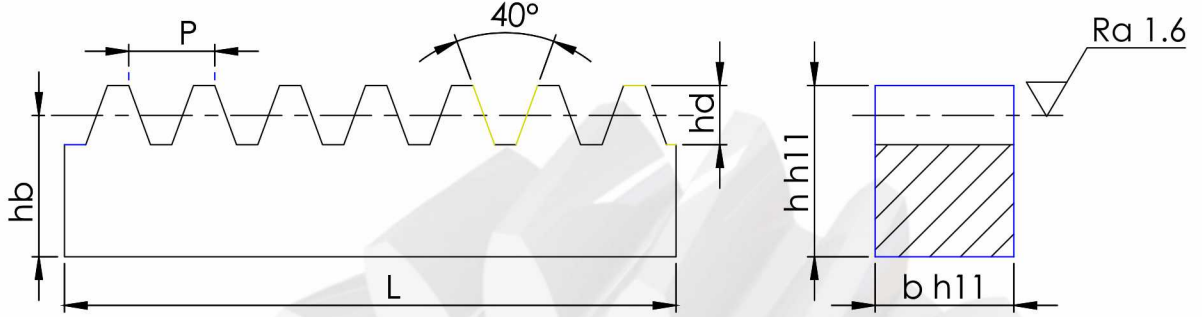

Malzeme - ck45 - C1040 - 4140
Kalite - Q7 hatve toleransı 0,003mm
Yüzeyi - frezelenmiş
Sertlik - İndüksiyon (Talebe göre)
40-55 HRC
BU ÜRÜNLER SİPARİŞ ÜZERİNE YAPILMAKTADIR.

Kod	Modül m	Diş z (1m'te)	Adım p	Kalınlık b	Yükseklik h	hb	hd	Boy L (metre)	Stok
55X55XM6-FR DÜZ	6	53	18.849	55	55	49	13	1-2-3	
55X55XM6-FR HLS	6	50	20.000	55	55	49	13	1-2-3	
65X65XM7-FR DÜZ	7	45	21.991	65	65	58	15,16	1-2-3	
65X65XM7-FR HLS	7	42	23.333	65	65	58	15,16	1-2-3	
75X75XM8-FR DÜZ	8	39	25.132	75	75	67	17,33	1-2-3	
75X75XM8-FR HLS	8	37	26.666	75	75	67	17,33	1-2-3	
95X95XM10-FR DÜZ	10	31	31.416	95	95	85	21,67	1-2-3	
95X95XM2,5-FR HLS	10	30	33.333	95	95	85	21,67	1-2-3	
115X115XM12-FRDÜZ	12	26	37.699	115	115	103	26,00	1-2-3	
115X115XM12-FRHLS	12	25	40.000	115	115	103	26,00	1-2-3	
155X155XM16-FRDÜZ	16	19	50.265	155	155	139	34,66	1-2-3	
155X155XM16-FRHLS	16	18	53.333	155	155	139	34,66	1-2-3	
190X190XM20-FRDÜZ	20	16	62.831	190	190	170	43,32	1-2-3	
190X190XM20-FRHLS	20	15	66.666	190	190	170	43,32	1-2-3	
-X-XM25	25	13	78.539	-	-	36	54,15	1-2-3	
-X-XM30	30	10	94.247	-	-	45	65,00	1-2-3	

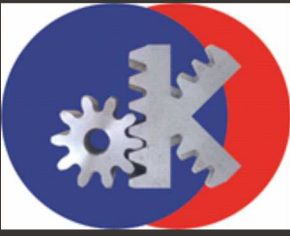

DÜZ PİNYON DİŞLİ ÖLÇÜLERİ

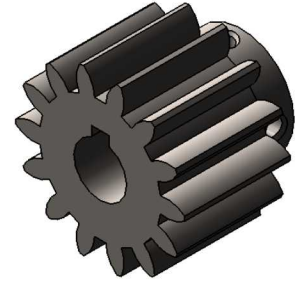
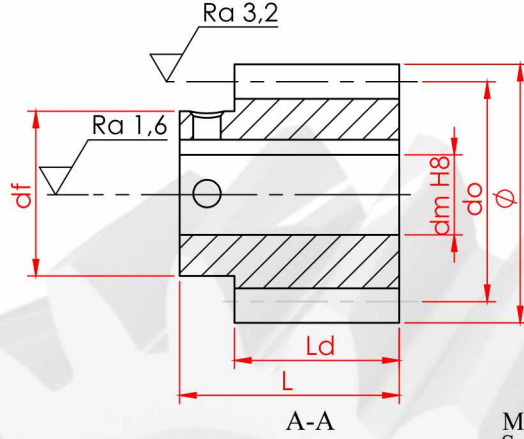
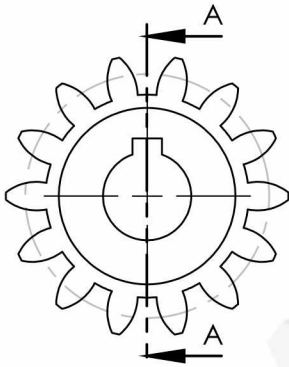

Malzeme : C1040 - C1050 - C4140
Sertlik : İsteğe bağlı induksiyon
40-55HRc

DÜZ PİNYON DİŞLİ ÖLÇÜLERİ

Kod	Mod.	Z	ϕ	L	Ld	df	do	dm H8	Kama	
m1z22-d	1	22	24	15	10	19	22	8	s	
m1z25-d	1	25	27	15	10	21	25	10	s	
m1z28-d	1	28	30	15	10	23	28	12	s	
m1,5z28-d	1,5	18	30	20	15	22	27	12	s	
m1,5z24-d	1,5	24	39	20	20	31	36	15	s	
m1,5z28-d	1,5	28	45	20	20	37	42	15	s	
m2z20-d	2	20	44	30	20	34	40	15	s	
m2z22-d	2	22	48	30	20	38	44	15	s	
m2z25-d	2	25	54	30	20	44	50	20	s	
m2z28-d	2	28	60	30	20	50	56	20	s	
m2,5z18-d	2,5	18	50	35	25	37	45	20	s	
m2,5z22-d	2,5	22	60	35	25	47	55	20	s	
m2,5z25-d	2,5	25	67,5	35	25	54	62,5	20	s	
m2,5z27-d	2,5	27	72,5	35	25	59	67,5	20	s	
m3z16-d	3	16	54	40	30	38	48	20	s	
m3z18-d	3	18	60	40	30	44	54	20	s	
m3z20-d	3	20	66	40	30	50	60	20	s	
m3z23-d	3	23	75	40	30	59	69	20	s	
m3z25-d	3	25	81	40	30	65	75	20	s	
m4z13-d	4	13	60	50	40	40	52	20	s	
m4z15-d	4	15	68	50	40	48	60	20	s	
m4z18-d	4	18	80	50	40	60	72	20	s	
m4z20-d	4	20	88	50	40	68	80	20	s	
m4z23-d	4	23	100	50	40	80	92	20	s	

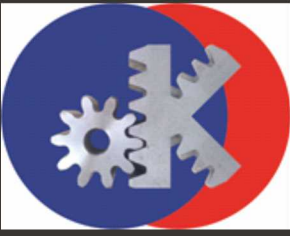

HELİS PİNYON DİŞLİ ÖLÇÜLERİ

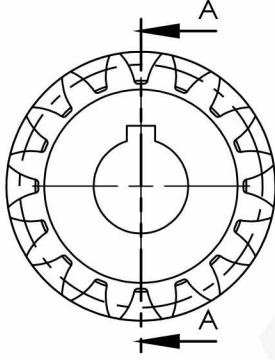

β 19° 31' 42"

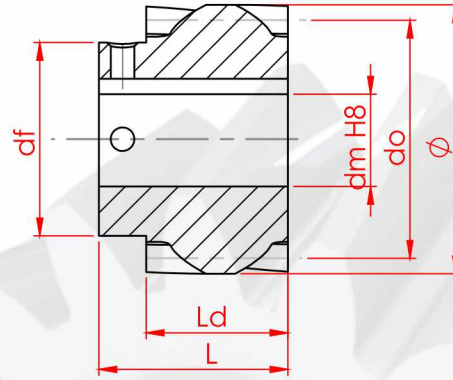

SECTION A-A



Malzeme : C1040 C1050 C4140
Sertlik : isteğe bağlı indüksiyon
40-55HRc

HELİS PİNYON DİŞLİ ÖLÇÜLERİ

Kod	Mod.	Z	ϕ	L	Ld	df	do	dm H8	Kama	
m1z22-h	1	22	25,46	15	10	19	22	8	s	
m1z25-h	1	25	28,64	15	10	21	25	10	s	
m1z28-h	1	28	31,83	15	10	23	28	12	s	
m1,5z28-h	1,5	18	31,83	20	15	22	27	12	s	
m1,5z24-h	1,5	24	41,38	20	20	31	36	15	s	
m1,5z28-h	1,5	28	47,75	20	20	37	42	15	s	
m2z20-h	2	20	46,68	30	20	34	40	15	s	
m2z22-h	2	22	50,93	30	20	38	44	15	s	
m2z25-h	2	25	57,29	30	20	44	50	20	s	
m2z28-h	2	28	63,66	30	20	50	56	20	s	
m2,5z18-h	2,5	18	53,05	35	25	37	45	20	s	
m2,5z22-h	2,5	22	63,66	35	25	47	55	20	s	
m2,5z25-h	2,5	25	71,62	35	25	54	62,5	20	s	
m2,5z27-h	2,5	27	76,92	35	25	59	67,5	20	s	
m3z16-h	3	16	57,3	40	30	38	48	20	s	
m3z18-h	3	18	63,66	40	30	44	54	20	s	
m3z20-h	3	20	70,00	40	30	50	60	20	s	
m3z23-h	3	23	79,57	40	30	59	69	20	s	
m3z25-h	3	25	85,94	40	30	65	75	20	s	
m4z13-h	4	13	63,66	50	40	40	52	20	s	
m4z15-h	4	15	72,15	50	40	48	60	20	s	
m4z18-h	4	18	84,88	50	40	60	72	20	s	
m4z20-h	4	20	93,37	50	40	68	80	20	s	
m4z23-h	4	23	106,10	50	40	80	92	20	s	

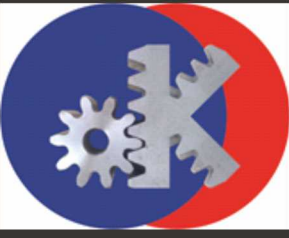

KRAMSAN MAKİNA MÜHENDİSLİK

PLATFORM - YÜK ASANSÖRÜ LİFT KRAMAYERLERİ

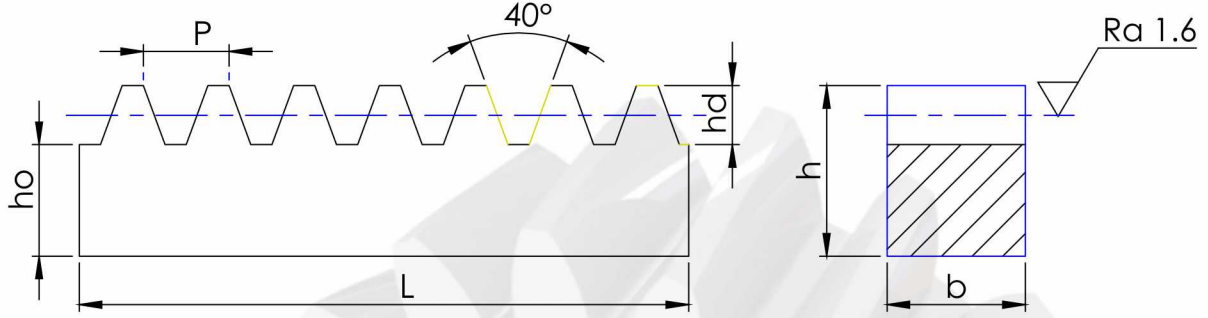

Malzeme Ç1040 sıcak çekme

MALZEME KALINLIK bxh	MODÜL	BOY L	STOK
30X30	7	1495	√
35X35	6	1187,5	√
40X25	6	1489	√
40X30	6	1489	√
40X30	7	1495	√
40X40	7	1495	√
40X60	8	1507,5	√



ANKARA

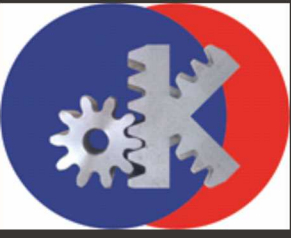

KRAMSAN MAKİNA MÜHENDİSLİK

HABERLER



- KESEL 2100 MN 20 CNC KRAMAYER ATÖLYEMİZDE YERİNİ ALMIŞTIR.
- MAX PARÇA ÖLÇÜLERİ 240x200x2100mm
- MAXİMUM MODÜL 20
- HELİS +-25 DERECE

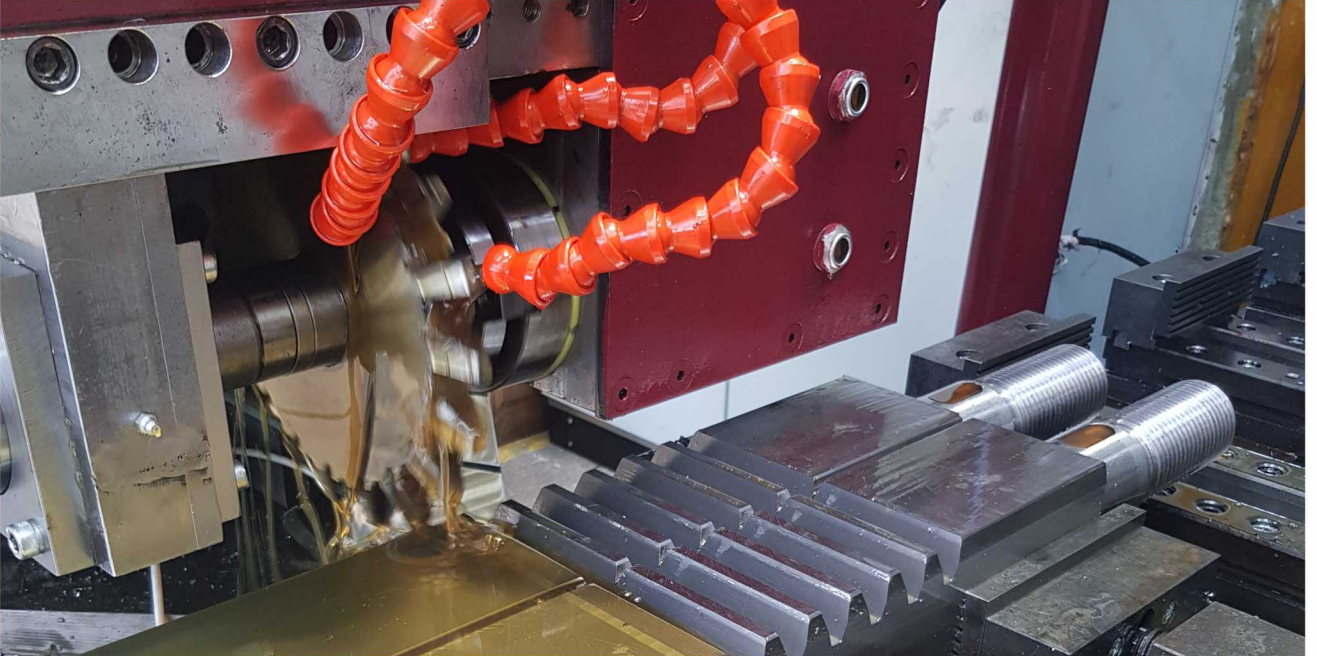

- KENDİ İMALATIMIZ OLAN KRS 3700 MN 30 CNC KRAMAYER TEZGAHI ATÖLYEMİZDE YERİNİ ALMIŞTIR.
- MAX PARÇA ÖLÇÜLERİ 300X350X3700mm
- MAX MODÜL 30
- KALİTE DİŞ BAŞINA 0,002mm
- HELİS +-25 DERECE

ANKARA

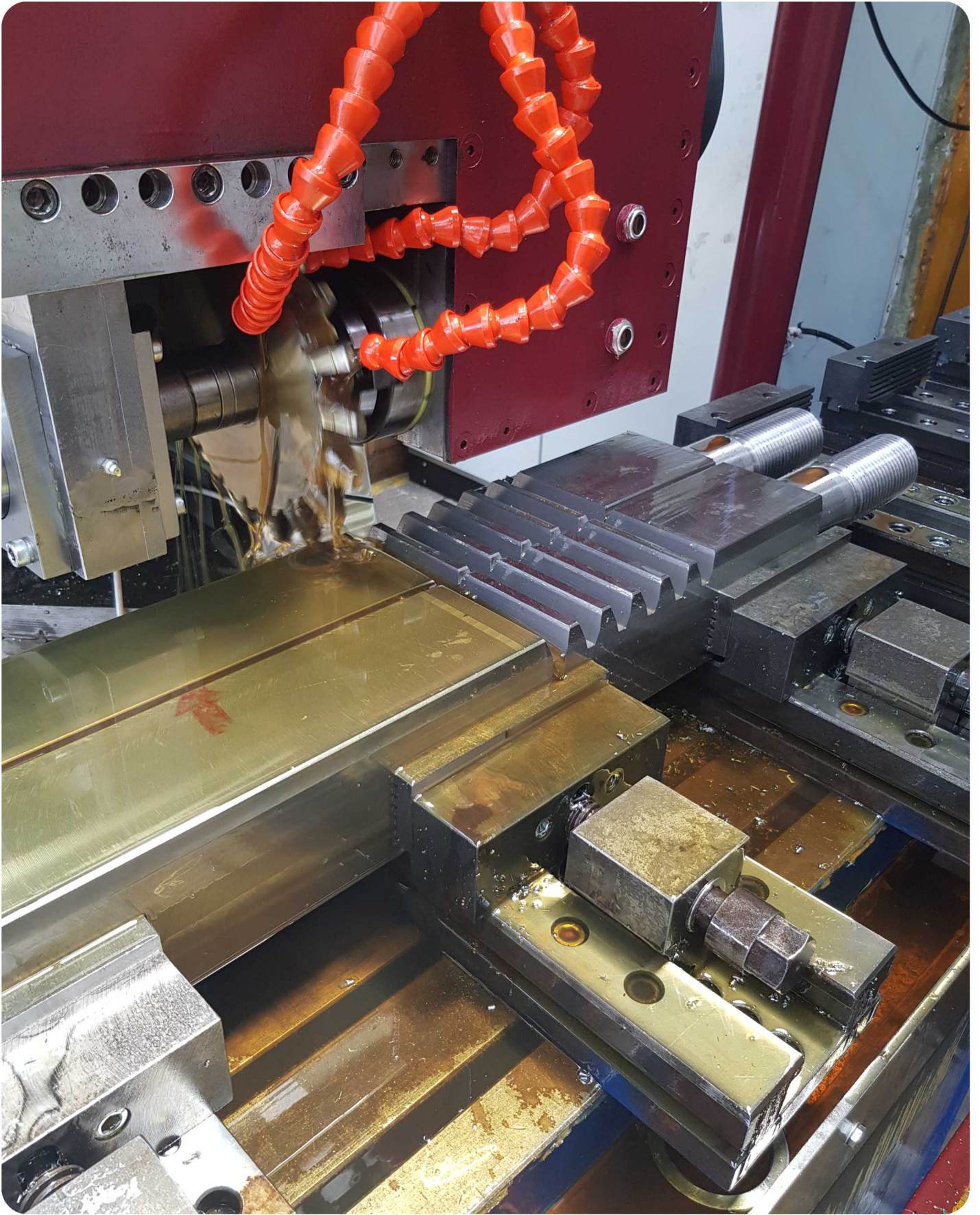

elml@jars 0535 232 08 87

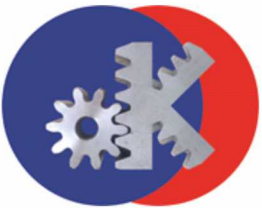

KRAMSAN
MAKINA MÜHENDİSLİK
www.kramsan.com

İvedik OSB Arı San. Sit. 1473.Cd. (Eski 690 Sk) No: 60
Yenimahalle / ANKARA

+90 312 394 41 81 • +90 505 209 02 06

info@kramsan.com • info@kramsankramayerdisi.com